



2884 SOUTH HORSESHOE DRIVE
NAPLES, FLORIDA 34104
OFFICES: TEL: (239) 643-0011 • (800) 493-0011
FAX: (239) 643-0940 • FAX: (239) 435-0198

T53 Engineering Product Support Notice – PT Bearing Heat Shield Repair

March 16, 2023



There is history of T53 PT Bearing Heat Shields failing, departing the engine and damaging the aircraft. This repair corrects the loose assembly fit for P/N 1-140-182-01 Heat Shield. Air Technology Engines has received FAA approval to address this problem to eliminate the potential of a heat shield vibratory failure and possible aircraft damage. Please review the attached instructions and advise if you have any questions.

This will improve engine reliability and safety

**John Moore
Mike Turner
Air Technology Engines, Inc.**

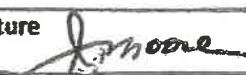

2884 SOUTH HORSESHOE DRIVE
 NAPLES, FLORIDA 34104
 OFFICES: TEL: (239) 643-0011 • (800) 493-0011
 FAX: (239) 643-0940 • FAX: (239) 435-0198

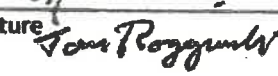
CAGE CODE: 08HK5		Page 1 of 5
OVERHAUL/REPAIR INSTRUCTIONS		
ATE-2090 REV. ORG. DATE: 2-15-23		
PART NUMBER: 1-140-182-01		
APPLICATION <input checked="" type="checkbox"/> COMMERICAL <input checked="" type="checkbox"/> MILITARY REPAIR <input checked="" type="checkbox"/> MINOR <input type="checkbox"/> MAJOR	DISTRIBUTION & RESTRICTIONS <input checked="" type="checkbox"/> ATE PROPRIETARY INFORMATION <input checked="" type="checkbox"/> ACCOMPLISHMENT OF THE REPAIR/REWORK.	DOCUMENTATION <input checked="" type="checkbox"/> MANUAL AFFECTED/MAINTENANCE MANUAL SECTION 72-40-00
REASON FOR INSTRUCTIONS/DESCRIPTION This repair is introduced to correct the loose assembly fit for the 1-140-182-01 Heat Shield that is allowing the cover to vibration during engine operation. See sheet page 2 for detailed repair instructions.		
Engine Model: T5313B Part Number 1-000-060-13 and T5317 Series Part Numbers 1-000-060-21,29,30,32 and T53L series.		
Approval Print Name and Sign		
ATE Engineering John Moore:	Signature 	Date: 3-1-2023
Mike Turner President/ Accountable Manager:	Signature 	Date: MARCH 1, 2023
Tom Rogozinski Airworthiness Representative:	Signature 	Date: 3/1/2023
DERT- <u>605483-NM</u>		

Changes to this Repair Specification: The FAA must authorize any changes to the repair specification before the applicant implements the change. The repair specification holder must submit all technical data to support the proposed change.

Provider of Superior Performing T53 Engines for 24 Years

Air Technology Engines (ATE) Repair Instruction

PT Cover, Exhaust Diffuser, 1-140-182-01

February 15, 2023

Repair Instruction Purpose, Reason, and References.

The current Maintenance Manual Instruction 72-40-00 introduced a loose (no cover plate rim contact) assembly fit for the 1-140-182-01 Heat Shield. This loose fit may allow the cover to vibrate during engine operation, leading to vibratory failure and ejection from the engine. In addition, the heat shielding intent to the PT Bearing Package may be reduced, causing higher Bearing and Seal operating temperatures. This ATE Repair Instruction restores the interference/pinch fit required (.010-.020 inch), and complies with the original Lycoming Engine Design Intent.

Repair Instructions.

1. Remove 1-140-182-01 PT Cover. Removal of 1-140-640-03 Rear Bearing Cover is Optional.
2. Inspect PT Cover 1-140-182-01 for dimensional and physical inspection. If physical surface damage is evident (bolt hole edge wear, outer circumference contact surfaces fretted and worn, bolt hole edge cracks i.e.) replace part. (No cracks acceptable)
3. PT Cover 1-140-182-01 Height -Dimension A, (See Illustration) Measure height from outer flange to raised center surface of PT Cover, record results as Dimension A in table provided.

PT Cover (Heat Shield)
1-140-182-01

(A) .392
.408



Recommended Method of Inspection - Dimension A

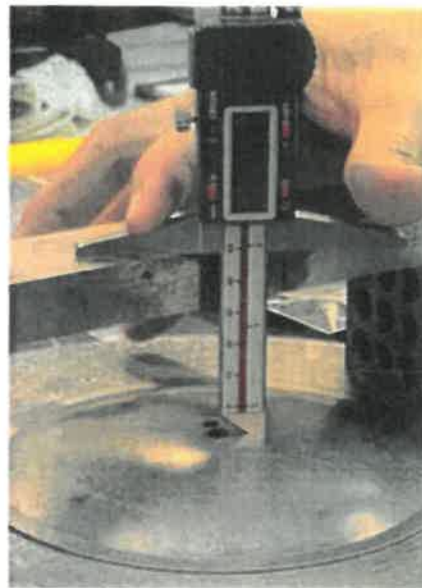
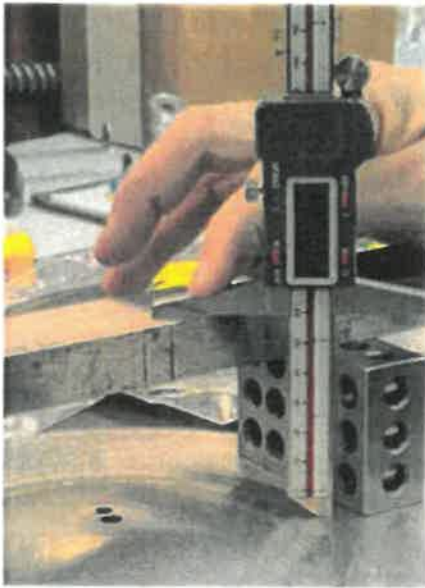

4. Rear Bearing Cover 1-140-640-03 Dimension B, (See Illustration) Measure height from outer rim to center of bearing cover and record as dimension B. NOTE: This can be accomplished with the rear bearing cover installed or removed from the engine (Shown as removed).

Rear Bearing Cover
1-140-640-03

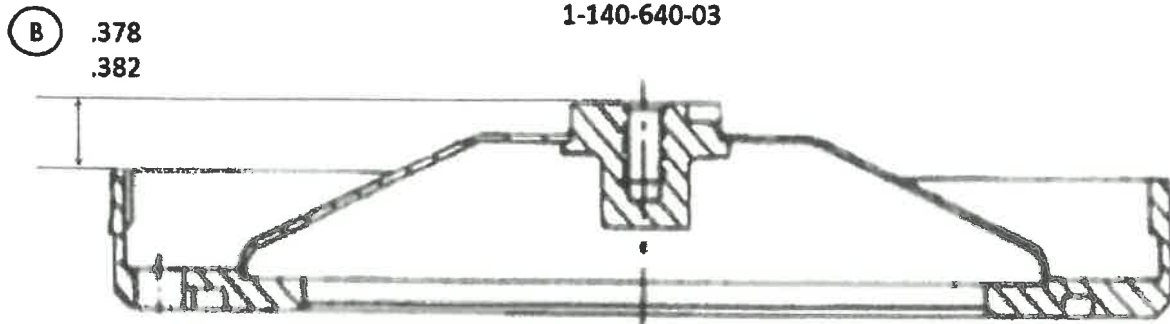

Recommended Method of Inspection - Dimension B



Dimension A _____

Dimension B _____

Dimension C _____

5. Subtract the recorded dimension on the 1-140-640-03 (Dimension B) from the recorded dimension on the 1-140-182-01 (Dimension A).

Pinch (Answer: Dim C) _____ (Pinch/ Interference fit of 0.010 to 0.020 inch)

Example: (Dim A) 0 .400 – (Dim B) 0 .380 = .020 inch (an interference/ pinch fit of .020 exists). AN INTERFERENCE FIT OF .010 to .020 inch is required.

NOTE: The PT Cover may be reworked to accomplish the desired pinch fit by mechanically pressing the inner bolt contacting surface while restraining the cover outer flange surfaces. This "press" pressure produces a dish increase/decrease dimension and the desired adjusted cover pinch.

If reworking the cover is not performed or preferred, replace the non-conforming cover with new part and confirm dimensionally acceptable per Repair Instructions 2. thru 5. above.

Re-assembly Instructions PT Cover

Re-assemble PT Cover using new bolt locking tab P/N 1-160-635-01. Confirm locking tab is properly engaged in anti-torque hole in cover. Torque cover retaining bolt to 95–100-inch pounds torque and safety wire.

NOTE: If Rear Bearing Cover is removed to accomplish this repair; install a new 1-300-462-01/02 seal in groove of cover, reinstall cover securing with 10 each STD3061-08 bolts and torque to 70 to 95 inch-pounds. Lockwire bolts and install PT Cover.

Record ATE Repair Instruction has been incorporated, date and operator name.

Operator Name: _____ Stamp _____ Date _____
